

NIMBUS™ II FLEX

2020 PRODUCT CATALOG

Includes Nimbus™ II Flex
ambulatory infusion system and
accessories.

P 1 508 650 2008

E orders@zynosolutions.com

www.zynosolutions.com

TABLE OF CONTENTS

About Zyno Solutions	02
Nimbus™ II Flex Ambulatory Pump	04
Administration Sets	06
Infusion Bags	07
Accessories	09
Ordering Information	11



WE ARE **ZYNO SOLUTIONS.**

Zyno Solutions is a trusted provider of intelligent infusion systems for the alternate care market. We provide industry leading products where there is a need for durable and advanced technology infusion systems.

The technologies that we offer provide the highest quality of care and patient safety along with our superior service and support. Our goal is to provide infusion systems designed specifically for the infusion needs of our customers.

Visit www.zynosolutions.com for more information.

AMBULATORY INFUSION PUMP

MEET THE FUTURE OF AMBULATORY INFUSION THERAPY.

The Nimbus™ II Flex Ambulatory Infusion System combines the accuracy of an electronic infusion pump with a simple and easy to understand interface for patient interaction.

This unique pump is engineered to be forward-thinking and capable of delivering advantages that meet the evolving needs of cancer care.

Product ID: IT1062



NIMBUS™ II FLEX PUMP PRODUCT SPECIFICATIONS

Product Dimension	4.25 x 2.28 x 1.5 (in), 108 x 58 x 40 (mm)	
Product Weight	6.14 oz, 174g	
Pump Mechanism	Linear Peristaltic	
Operating Mode	Continuous mode	
Max. Infusion Pressure	30 psi	
Max. Time to Occlusion Alarm	20 minutes	
VTBI	1 - 1500mL by 0.1mL increment (single infusion VTBI maximum value is limited by remaining pump lifetime VTBI)	
Rate	0.1 mL/h - 135 mL/h in 0.1mL/h increment	
Flow Rate Accuracy	+/- 5%	
Power Supply	AC/DC via Micro USB port, internally powered by battery (battery not rechargeable)	
Battery Life	400 h or 1500mL of volume infused	
Alarms	<ul style="list-style-type: none"> • Cassettes loading error • System error • Firmware error • Upstream occlusion • Downstream occlusion • Battery Depleted 	<ul style="list-style-type: none"> • Invalid infusion parameter • Pump unattended • Infusion complete • Power off and replace battery • Due for service
Warnings	Battery low	
Administration Set Options	<ul style="list-style-type: none"> • Bag spike • Set-based free flow protection • Slide clamp 	<ul style="list-style-type: none"> • 1.2 micron filter (air eliminating) • Luer lock adaptor
Optional Accessories	Carrying pouches for pump, Drug bag, Hardshell	
Standards	Electrical Safety: IEC 60601-1 Pump Performance: IEC 60601-2-24 Electromagnetic Compatibility: IEC 60601-1-2 Usability and Human Factor: IEC 60601-1-6 ed3/ IEC 62366 Alarm System: IEC 60601-1-8 Home Healthcare Environment: IEC 60601-1-11	

Nimbus™ II Flex includes the infusion pump, Clinician IFU booklet, and Patient IFU booklet. For Clinician and Patient Quick Reference Guide, please order separately.

PRODUCT ID	PRODUCT NAME	QTY
IT1062	Nimbus™ II Flex	1
	Clinician IFU booklet	1
	Patient IFU booklet	1
SOL211	Clinician Quick Reference Guide	1
SOL212	Patient Quick Reference Guide	1



ADMINISTRATION SETS

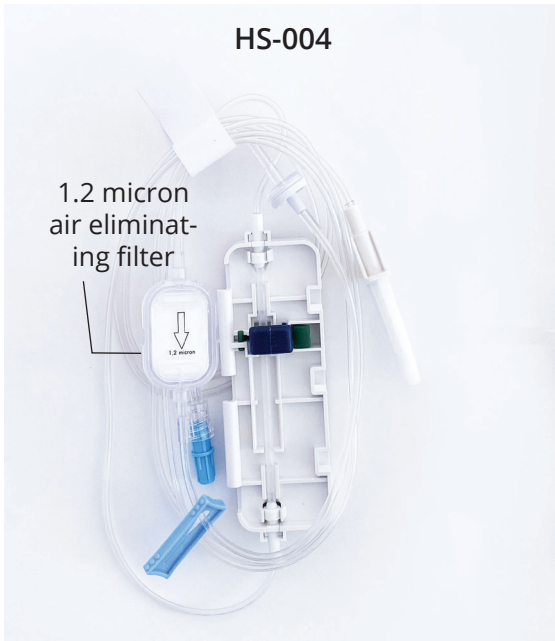

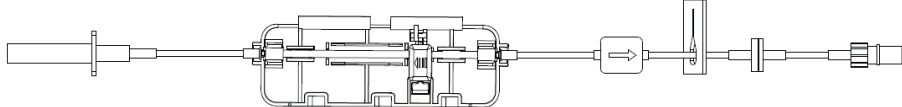
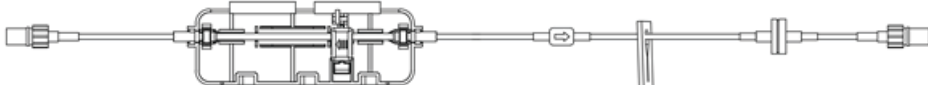
PRODUCT ID	DESCRIPTION	LENGTH	QTY
HS-004	 <p>spike cap, spike, cassette, anti-free-flow clamp, 1.2 micron air eliminating filter, slide clamp, backcheck valve, male luer lock adaptor, and luer cap.</p>	67" (170cm)	20/ case
HS-008-B	 <p>luer cap, male luer lock adaptor, cassette, anti-free-flow clamp, 0.2 micron air eliminating baby filter, slide clamp, backcheck valve, male luer lock adaptor, and luer cap.</p>	57" (145cm)	20/ case

The Nimbus Administration Set is designed to administer fluids/medication from a container to a patient through a needle or catheter. The fluid path is sterile (EtO sterilized), non-pyrogenic, not made of DEHP, not made with natural latex. The set is single use only.

IV INFUSION BAGS

FOR YOUR DIFFERENT INFUSION NEEDS

The Secure® Bag comes in five different sizes to fit your different infusion needs: include 50mL, 100mL, 250mL, 500mL, and 1L.



SAFE & DURABLE

- Container made with EVA (Ethyl Vinyl Acetate)
- NO natural rubber latex and DEHP
- Secure and durable handle
- Each comes with two ports:
 - safe injection port for medication
 - bag spike port for patients

PRODUCT ID	PRODUCT NAME	QTY
SOL202	50mL Secure® Bag	50/case
SOL201	100mL Secure® Bag	50/case
SOL203	250mL Secure® Bag	50/case
SOL206	500mL Secure® Bag	50/case
SOL207	1000mL Secure® Bag	50/case



IV INFUSION BAGS

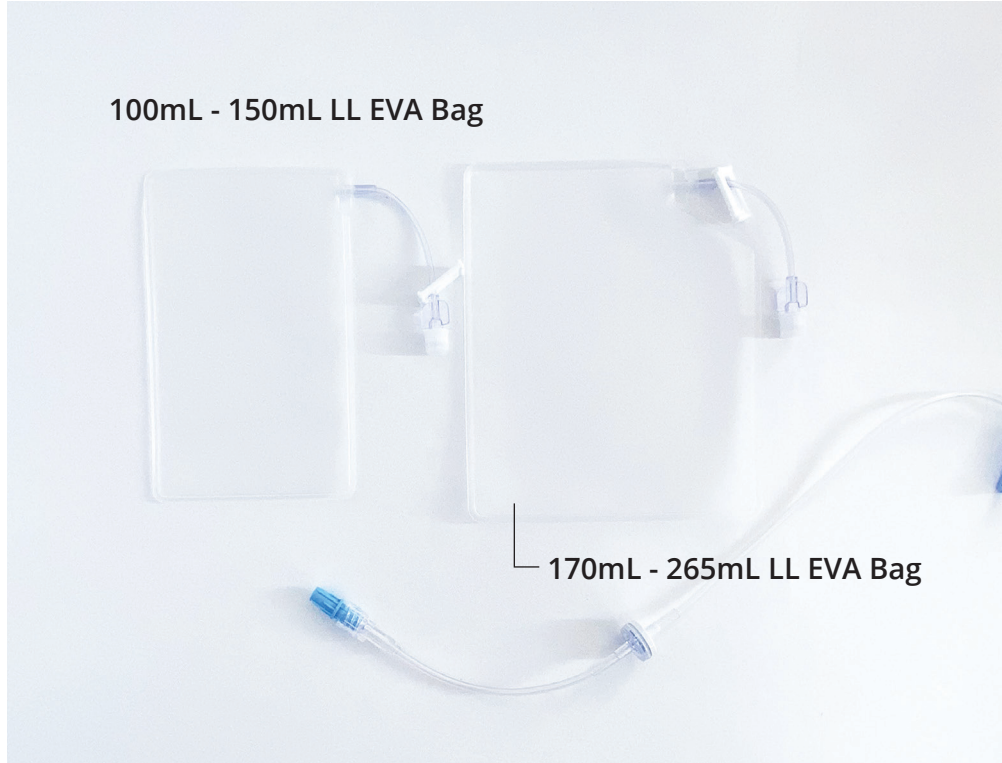

100mL - 150mL LL EVA Bag
Product ID: SOL237

This EVA bag is made to use for 110mL fill with or without 100ml hardshell case.

170mL - 265mL LL EVA Bag
Product ID: SOL238

This EVA bag is made to use for 250mL fill with or without 250ml hardshell case.

PRODUCT ID	PRODUCT NAME	QTY
SOL237	100mL - 150mL LL EVA Bag - ACTA Medical	50/box
SOL238	170mL - 265mL LL EVA Bag - ACTA Medical	50/box

ACCESSORIES



IT'S A PERFECT FIT!

The Nimbus carry pouches are designed to fit our Nimbus pump and medication bag, so everything a patient needs is in one place, making it easy to bring it anywhere.

Our unique triac pouches are designed to be used with hardshell cases.

Please read the product description below to find the proper fit.



PRODUCT ID	PRODUCT NAME	PRODUCT DESCRIPTION	QTY
SOL224	100mL Pouch	Designed to fit Nimbus pump and 50mL medication bag	1
SOL251	100mL Hard Shell Pouch	Designed for use with 100mL Hardshell case	1
SOL225	250mL Pouch	Designed to fit Nimbus pump and 100mL medication bag	1
SOL252	250mL Hard Shell Pouch	Designed for use with 250mL Hardshell case	1
SOL226	500mL Pouch	Designed to fit Nimbus pump and 250mL medication bag	1
SOL227	1000mL Pouch	Designed to fit Nimbus pump and 500mL and 1L medication bag	1

ACCESSORIES

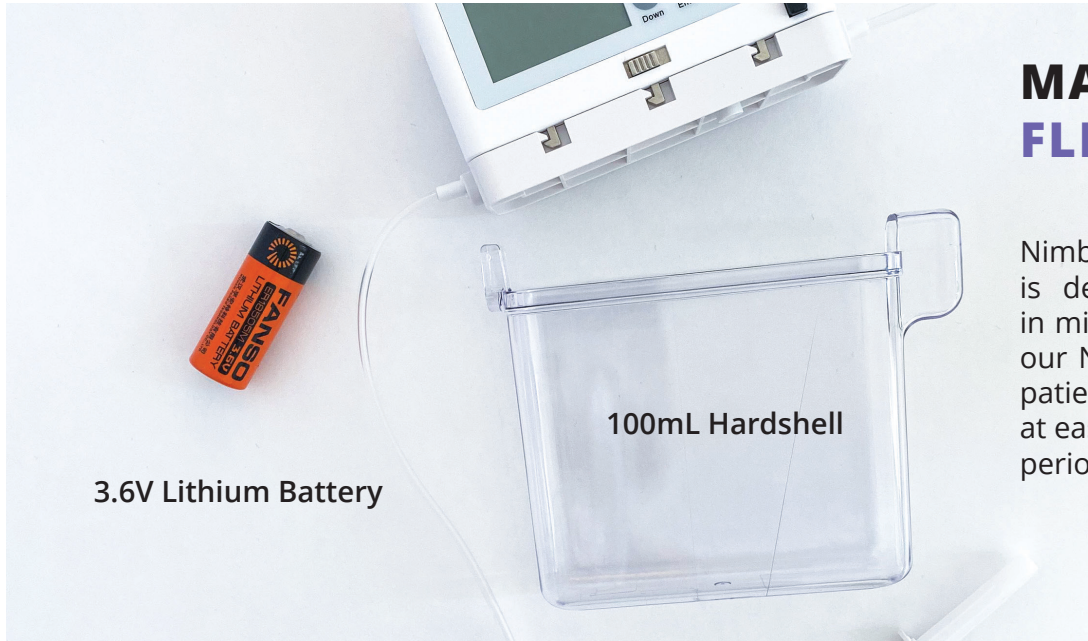

3.6V Lithium Battery

100mL Hardshell

MADE FOR FLEXIBILITY

Our tamper-resistant Nimbus™ II hardshell case is designed with patients in mind. With it attached to our Nimbus™ II Flex pump, patients can move around at ease during long infusion periods.



250mL Hardshell



Chemo Spill Kit
The kit includes absorbant bio-wipe bag, pair of chemo gloves, chemo bag and spill kit instructions.

PRODUCT ID	PRODUCT NAME	QTY
IT1069	Fanso ER18505M 3.6V lithium battery	1
SOL228	Nimbus™ II Hardshell - 100mL size	1
SOL244	Nimbus™ II Hardshell - 250mL size	1
SOL234	Chemo Spill Kit	1



FIND YOUR **INTELLIGENT** **INFUSION SYSTEM**

GET IN TOUCH WITH OUR CUSTOMER SERVICE TEAM

P 1 (508) 650 2008

F 1 (508) 650-2006

E orders@zynosolutions.com

www.zynosolutions.com

Hours: 8 AM - 5 PM, Monday to Friday

For technical support, please contact 866-395-1988 or techsupport@zynosolutions.com.

Preventative Maintenance

Customer is responsible for annual preventive maintenance procedures as required by the manufacturer. Zyno Solutions cannot assure safe use of the infusion pump if the customer fails to follow such procedures.

Administration Sets

Only manufacturer tubing is tested and calibrated for its products.



P +1 508 650 2008

E info@zynosolutions.com

A 177 Pine Street Natick MA 01760 USA

www.zynosolutions.com

ZYS-CT2F-002 Rev E