



ADULT HOMECARE HANDBOOK

Shiley™ Trach Tube Solutions

Medtronic
Further. Together

Read before using this homecare handbook

Caution: This handbook is intended to serve as a reference guide for the use and care of Shiley™ trachestomy (trach) technology from Medtronic and should not replace institutional policies or doctors' orders.

Use of these guidelines with other trach products is not recommended. You should always follow your doctor's or hospital's directions if they differ from those found here.

Warning: Shiley™ trach tubes are sterile if not opened, damaged, or broken. Do not resterilize Shiley™ trach tubes. All Shiley™ trach tubes are designed to be single use, for one patient, and disposable.

Note: Federal law restricts Shiley™ trach tubes to sale by, or on the order of, a doctor.

Disclaimer: For detailed instructions, specifications, warnings, and additional information on Shiley™ trach tubes, please refer to the instructions for use (IFU) provided with the product.

What's inside

This handbook provides information on how to care for your Shiley™ trach tube. You will find tips on how to suction, change ties, change tubes, and care for the skin around the opening in your neck. Also included are basic safety tips, a problem-solving guide, and an easy-to-understand glossary of the technical terms you may hear. For product specific information, please review the instructions for use (IFU) that is included in each product package.

Review safety tips and notes

On page 3, and throughout this handbook, are a number of safety tips and notes designed to warn about conditions that could be potentially harmful. There are other notes that warn about situations that could damage your Shiley™ trach tube. Take a moment to review these tips and notes before you begin your trach tube homecare.

Important phone numbers

Doctor _____

Home care provider _____

Home care supplier _____

Emergency _____

How the Tracheostomy Works	4
What Changes Occur	
Safety Tips	5
Getting Ready to Go Home	6
What You Will Need	
Tips for Daily Living	7
Humidification, Bathing, Illness, Clothing, Getting Out	
What You Will Need in a Travel Kit	
Suctioning	8
What You Will Need	
How to Suction	9
Changing Ties	11
What You Will Need	
How to Change Twill Tape Ties	
Skin Care	12
What You Will Need	
How to Clean Around the Opening	
Changing the Tube	13
What You Will Need	
How to Change a Cuffed Tube	
How to Change a Cuffless Tube	
Inner Cannula Care	17
What You Will Need	
Reusable Inner Cannula Care	
(CFN, CFS, FEN, LGT, LPC)	
Replacing a Disposable Inner Cannula	
(DCFN, DCFS, DCT, DFEN, PERC)	
Trach Tube Cleaning Reference Guide	20
Solving Problems	21
Product Description	23
FEN and LPC	
CFN, CFS, and LGT	
DCT, DFEN, and PERC	
DCFN and DCFS	
SCT	
Speaking Valve	28
Glossary	31

The most common reasons for performing a tracheostomy are to bypass an airway blockage or to provide long-term mechanical ventilator support. The doctor makes an opening (stoma) through the skin and tissue of the neck into the windpipe (trachea). Then a curved plastic tube (trach tube) is placed into the opening through which you breathe.¹

What Changes Occur

While the tracheostomy tube is a wonderful aid to help you breathe better, it requires care and some changes in the way you do things. When you breathe through your nose and mouth, the air is filtered, warmed, and moistened before it gets to your lungs. With a trach tube, air goes directly into your windpipe and to your lungs without being filtered, warmed, or moistened.² You will learn how to make up for this by using the proper equipment and by learning proper trach tube care.

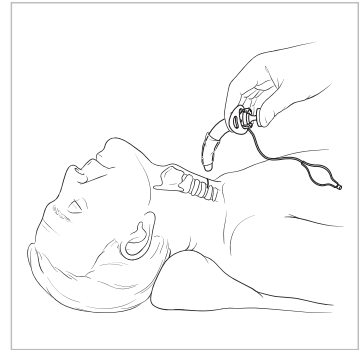
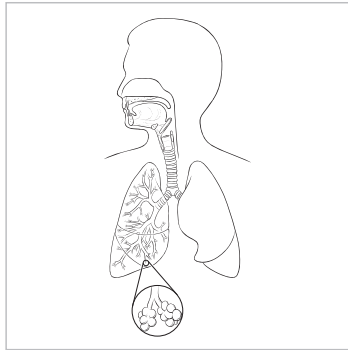

If you use a ventilator



Routinely check the ventilator safety and audio alarms to be sure they are working properly.

Be sure the ventilator tubes are properly placed so that they don't pull on the trach tube.

Don't twist or pull on the trach connector any more than you must. This may cause discomfort or disconnect the ventilator tubes.

Hold the trach tube in place when connecting or disconnecting the ventilator or humidification tubing.

When using a ventilator with a fenestrated trach tube, always use a non-fenestrated inner cannula with a 15 mm connector as recommended by your doctor.

Follow your doctor's or hospital's directions for care. If instructions in this guide are different from your training, follow your training.

Review with your doctor and/or home healthcare provider the various features and accessories for your Shiley™ trach tube. Carefully read the instructions for use booklet included in each product package.

Only people who have been trained by a healthcare professional should perform trach care.

Always have extra trach tubes on hand for an emergency (one the same size and one smaller).

Do not resterilize Shiley™ trach tubes or attempt to clean them in boiling water. They are designed for single use only up to 29 days.

Don't place the plastic trach tube anywhere the temperature is over 120°F.

If you have a cuffed trach tube, avoid overinflating the cuff. This can damage your windpipe. It may also cause the cuff to extend past the end of the tube where it can restrict or block air flow.

Watch for these signs of infection, and notify your doctor if present:

- Red, inflamed skin at stoma
- Foul-smelling mucus
- Bright red blood in mucus

If you are unable to remove your trach tube, or if you are unable to remove the inner cannula, do not force it. Call your doctor.

Remember to:

- Avoid dust and mold
- Avoid tobacco and other kinds of smoke
- Avoid fumes from cleaning solutions such as ammonia or bleach
- Be careful using any kind of spray product, such as hairspray, furniture polish, etc.; you do not want to inhale the mist
- Keep clothing away from the trach tube except for a protective scarf
- Be sure all caregivers know CPR for trach patients. Hang CPR instructions where they will be handy in an emergency
- Have emergency numbers available in case they are needed

What you will need

- Blunt-nose scissors
- Box of facial tissues
- Container (for catheter rinse water)
- Cotton swabs
- Disposable gloves
- Hydrogen peroxide
- Syringe (if you have a cuffed tube)
- Precut trach dressing
- Replacement trach tubes (one the same size and one smaller)
- Small wash basin
- Sterile 4 x 4 in. gauze pads
- Sterile normal saline or distilled water (to soften mucus so that it may be suctioned)
- Suction catheter Suction machine with connecting tubing
- Trach tube mask (optional)
- Twill tape or other trach tube holder (to secure the tube in place)
- Water-soluble lubricant

Getting ready to go home

Your trach tube gives you the freedom to leave the hospital and resume your life at home. However, they will require regular care to ensure that it works correctly. That is why you will receive training in the hospital.

Ask plenty of questions and take notes during your hospital training sessions. Make sure you understand the proper methods of trach tube care. Practice every chance you get with the help of your instructor. The more practice you have, the more confident and comfortable you will be once you go home.

Have family members or a friend attend the instruction at the hospital so that they can help you if needed. It is always good to have someone you can turn to for help if you are sick or if there is an emergency.

Your doctor, nurse, or therapist is your best source for advice. This handbook will provide helpful tips and reminders so that things can go smoothly once you are home again.



Note: Some items come from your home healthcare supplier; others you will need to buy at the store.

What you will need in a travel kit

- Blunt-nose scissors
- Breathing medications (if you use them)
- Manual resuscitation bag (if ordered by doctor)
- Portable suctioning device
- Spare trach tubes with obturator and ties (one the same size and one smaller)
- Suction catheter
- Tissues



Note: Appropriate humidification, when indicated, helps ensure that the cannula and fenestration remain open and function properly.

Humidification

Normally, your nose and mouth would moisten the air you breathe to protect the lining of your lungs. With a trach tube, you have to moisten the air another way. That's why it is important to drink plenty of liquids and use a humidifier or an "artificial nose" to moisten and warm the air before going into the lungs.²

Bathing

While a little moisture is good, too much can cause problems. So, when you shower, direct the shower spray at chest level and place a shower shield or protective covering over your trach tube. Be careful to keep soap and water away from the tube and stoma when washing your face. Also, take care to cover your trach tube when you are shaving or using powders, hair spray, etc., around your face and neck.²

Illness

For trach patients, eat a healthy diet, get plenty of rest, and avoid contact with people who have colds or infections.

If illness occurs, you may need to suction more frequently. Be sure to get plenty of fluids, particularly if you have symptoms of fever, vomiting, or diarrhea. If you vomit, cover the trach tube with an artificial nose or towel to keep vomit out of your airway. If you think vomit may have entered the trach tube, suction immediately.²

Clothing

The main concern about clothing is that it does not block the trach tube. Avoid crew necks and turtlenecks in favor of V-necks and open collar shirts or blouses. Also, do not wear clothes that shed fibers or lint.

Getting Out

If your doctor says you can leave home to go shopping or visit friends, do it. It is a wonderful break from the routine, and it will lift your spirits. Just take along a travel kit (see above).

If it's very cold outside, be sure to wear an artificial nose or loosely cover the trach tube with a scarf, kerchief, or gauze. This helps to warm the air as you breathe, so that the cold air doesn't irritate your windpipe and lungs. It also helps keep out dust or dirt on windy days.²

Read before suctioning



Note: Always follow your doctor's or hospital's directions if they differ from the directions in this handbook. Carefully review with your doctor or home healthcare provider the appropriate recommendations to determine the appropriate size suction catheter for your tube. The following table can be used as a guide to help select the suction catheter size based on the internal diameter of the tube.

Note: before suctioning a fenestrated tube, make sure the non-fenestrated inner cannula is in place.

Note: if you require removal of pooled secretions above the cuff, follow the instructions of your doctor or home healthcare provider.



The lungs and windpipe naturally produce mucus. The mucus cleans the air as we breathe by trapping small particles. It then moves up the windpipe until it can be swallowed or coughed out.

With a trach tube, mucus can collect in and around the trach tube. This mucus must be removed so it doesn't dry and block the tube. How frequently you suction will be determined by the amount of secretions that you have and by your doctor or home healthcare provider.²

Trach Tube Internal Diameter	Suction Catheter
5.0 mm	10 Fr.
5.5 mm	10 Fr.
6.0 mm	10 Fr.
6.5 mm	12 Fr.
7.0 mm	14 Fr.
8.0 mm	14 Fr.
9.0 mm	14 Fr.

What you will need

- Collection jar for secretions
- Container for water
- Disposable gloves
- Distilled water or saline
- Suction catheter
- Suction machine

Read before suctioning



Note: Follow the hospital or home healthcare provider's instructions for storage, use, and disposal of suction catheters. Also, keep the suction machine, tubing, and collection jar clean according to the home healthcare provider's instructions.

Note: It is common to see suctioning using a sterile technique in hospitals. In the home setting, a clean technique may be used. Discuss this with your home healthcare provider.

Follow this suction procedure only if directed by your physician.

1. Wash hands.
2. Put on gloves.
3. Attach suction catheter to suction machine.
4. Rinse catheter by suctioning sterile water.
5. Hyperoxygenate by taking 3 to 4 deep breaths.
6. With your thumb off the thumb hole, gently insert the catheter into the trach tube until it reaches the end of the tube or until you cough.
7. Cover the thumb hole on the catheter to suction.
8. Slowly remove the catheter while rolling it between your thumb and pointer finger. Also pulse the suctioning by covering and uncovering the thumb hole of the catheter. (Start to finish, this process should take no longer than 10 seconds.)
9. If you need to suction again, rinse the catheter in sterile water first and take another 3 to 4 deep breaths, then repeat the suctioning stage. (Allow enough time between each catheter insertion for normal breathing or ventilator support to re-oxygenate your body.)
10. Look at the mucus you have suctioned. Normal: Clear, with no odor. Infection: Yellow or green color with foul-smelling odor. Blood: A few streaks of blood is OK. But if it has more bright red or old dark blood, call your doctor.
11. If you see signs of infection or bright red blood, call your doctor.



7



10

Read before changing ties



Caution: If you use a cuffed tube, protect the inflation line when cutting the ties.

Note: Change the location of the knot to prevent skin irritation.



What you will need

- Blunt-nose scissors
- Disposable gloves
- Twill tape or Shiley™ trach tube holder

It is important to keep the area around the stoma clean to help prevent infection. So, change ties daily or whenever they become wet, dirty, or loose.

How to Change Twill Tape Ties

1. Wash hands. (An assistant, if present, must wash hands, too.)
2. Leave old ties in place. Pull one end of the twill tie (under the old ties) through either neck flange hole. Adjust the ends of the tie until one is 3 to 4 inches longer than the other.
3. Bring both ends of the tie around your neck and insert the longer end of the tie through the other neck flange hole.
4. Pull the tie snug. Place one finger between the tie and the neck and tie the two ends together using a square knot. Do not use a bow.
5. Cut the ends of the ties leaving only 1 or 2 inches.
6. Carefully cut and remove soiled ties.



3



4

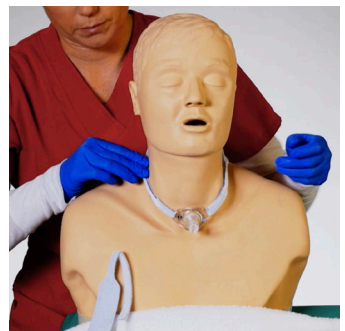

5

Read before cleaning around the opening



Caution: Watch for red, irritated areas. If excessive redness or pimples occur around the opening, call your doctor, reduce humidity delivered around the opening, and use only sterile water for cleaning. Do not use over-the-counter, petroleum-based creams like zinc oxide or Vaseline™ products around the opening. If your doctor prescribes an ointment, apply it according to his or her instructions.



What you will need

- Cotton swabs, Hydrogen peroxide and sterile water (mixed in equal parts)
- Precut trach dressing, if required
- Sterile gauze pads

Skin care is easy but very important. It should be done at least twice a day: once in the morning and once at night. If you smell an odor around the neck or stoma, clean the area every eight hours until the odor is gone.

How to clean around the opening

1. Wash your hands.
2. Dip a cotton swab into the hydrogen peroxide and water mixture.
3. Roll the cotton swab between the trach tube and the skin around the stoma. Clean from the stoma outward. This removes wet or dried mucus.
4. Repeat steps 2 and 3 using a fresh cotton swab each time, until entire area around the stoma is clean.
5. Rinse the area using a clean cotton swab dipped in clean water only.
6. Use a dry gauze pad to pat lightly around the opening.
7. Replace the trach dressing, if required.



3

Read before changing any tube



Caution: Frequent and routine changes of the trach tube are recommended. Shiley™ trach tubes should not be used more than 29 days and should be replaced and discarded per your doctor's instructions.

Note: Always follow your doctor or hospital's directions, if they differ from the directions in this handbook. Do not attempt to change your trach tube unless you have been trained to do so. Contact your doctor or hospital with any questions you may have.

Note: Always keep complete, sterile replacement trach tubes handy (one the same size and one smaller) in case of an emergency.

Note: Shiley™ trach tubes are designed for single-patient use only and cannot be resterilized by any method.

Caution: Carefully read and understand the Instructions for Use packaged with each trach tube before using it.

Changing your trach tube at the recommended intervals helps to ensure proper operation of your Shiley™ trach tube. Your tubes should not be used more than 29 days and should be replaced and discarded per your doctor's instructions.

How to change a cuffed tube

1. Wash hands. Put on gloves.
2. Take the replacement trach tube out of its container. Take care to avoid damaging the cuff, inflation line, or pilot balloon. Remove the inner cannula, if it is in place.
3. Use a clean, dry syringe to inflate the cuff to the proper leak test volume. The markings on the syringe show air volume. The following are test volumes only. Your doctor will tell you the appropriate inflation volume to use when the tube is in your trachea.
4. Place the entire tube, including inflation line, in a small wash basin with enough sterile water to cover it, and watch for bubbles indicating an air leak.

Shiley™ Tube Size	Leak Test Volume
10	20 cc
8	17 cc
6	14 cc
4	11 cc



2



4

Read before changing a cuffed tube



Note: During the leak test, if you see any air leaks, do not use the tube.

Caution: Carefully air-dry the inflation line before inflating to ensure no water enters when you inflate the cuff.

Caution: Do not use anything sharp while handling the cuff to avoid causing damage to it.

Note: Do not use petroleum-based products, such as Vaseline™ jelly, to lubricate your tube.

Note: If you have a fenestrated tube, insert the inner cannula before inflating the cuff.

Note: If you use a fenestrated tube, make sure the cuff is fully deflated prior to using a decannulation plug.



5. Deflate the cuff completely using a syringe. As you are doing this, gently push the cuff away from the end of the tube. Be sure to remove all air. (This makes it easier to insert the tube.)
6. Insert the ties through one neck flange hole (under the old ones). Insert the obturator into the cannula. (Do this before inserting the tube.)
7. Lubricate the tube using a thin layer of water-based lubricant.
8. Place the tube on a sterile surface.
9. If required, suction secretions that might have pooled above the cuff of the old tube. Follow your doctor's or hospital's directions for this procedure.
10. Deflate the cuff completely using the syringe, cut the ties, and remove the old tube.
11. As you breathe in, gently insert the new tube, pushing back and then down in an arcing motion.



6



8

What you will need

- Blunt-nose scissors
- Disposable gloves
- Precut trach dressing
- Replacement trach tube
- Small wash basin
- Sterile 4 x 4 in. gauze
- 10 cc syringe (for cuffed tubes)
- Twill tape or Shiley™ trach tube holder
- Water-based lubricant



10

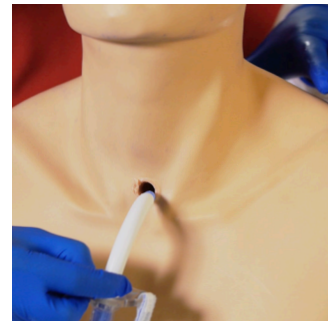

11

12. Immediately remove the obturator, while holding the tube in place with your fingers.
13. Insert the new inner cannula making sure that it is properly secured in place. If you use a twist-lock inner cannula, it is secure when you feel it lock into place and the blue dots on the inner and outer cannulae are lined up. If you are using a disposable inner cannula, make sure that both sides of the winged flange are snap-locked securely in place.
14. Inflate the cuff to the proper volume using a syringe. (Your doctor will tell you what volume to use.)
15. Finish fastening the ties as described on page 9.
16. Throw away the old tube.

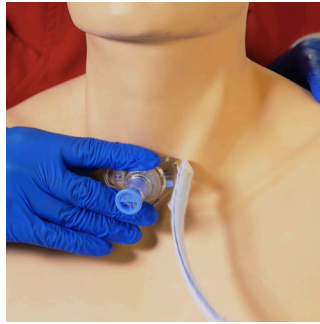

12

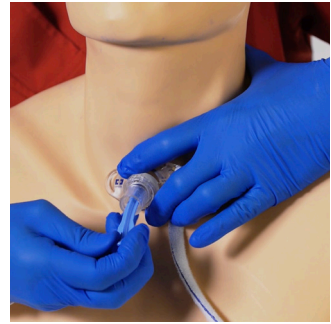

13



13



13

Read before changing your tube



Note: You probably won't have trouble inserting the new tube. But if you do, be sure your head is tilted back as you insert the tube. If you are still having difficulty, spread the skin around the stoma and insert the tube as you are breathing in or use a fresh tube that is a size smaller. Call your doctor immediately if you have any problems.

How to change a cuffless tube

1. Wash hands. Put on gloves.
2. Insert the ties through one neck flange hole (under the old ones). Insert the obturator into the cannula. (Do this before inserting the tube.)
3. Lubricate the tube using a thin layer of water-based lubricant.
4. Place the tube on a sterile surface.
5. If required, suction secretions.
6. Cut the ties and remove the old tube. If you are unable to remove it, call your doctor. Do not force it.
7. As you breathe in, gently insert the new tube, pushing back and then down in an arcing motion.
8. Immediately remove the obturator, while holding the tube in place with your fingers.



2

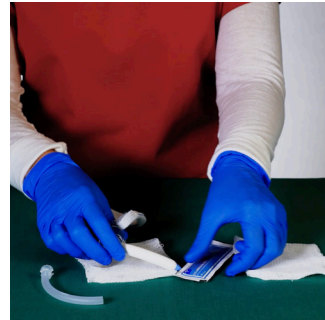

4



7

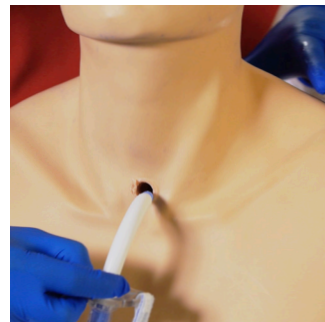

8

9. Insert the new inner cannula making sure that it is properly secured in place.
10. If you use a twist-lock inner cannula, it is secure when you feel it lock into place and the blue dots on the inner and outer cannulae are lined up. If you are using a disposable inner cannula, make sure that both sides of the winged flange are snap-locked securely in place.
11. Finish fastening the ties as described on page 9.
12. Throw away the old tube.

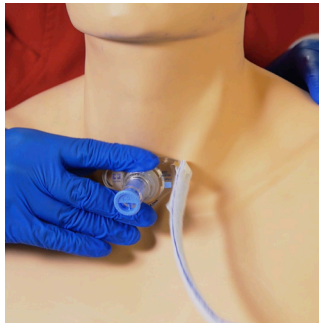

9

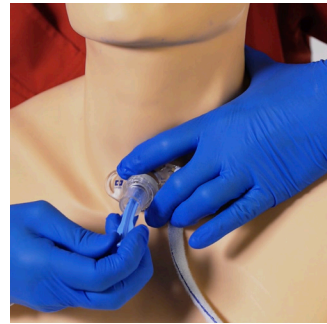

10



10



11

Read before starting inner cannula care



Note: The cleaning procedure should be clearly understood before proceeding. Follow your physician's recommendations for the cleaning procedure and schedule. The listed procedure is to be used only if your physician instructs you to.

Note: The spare inner cannula (SIC) should not be used as a replacement for the inner cannula provided with your trach tube.

Note: To loosen dried-on mucus, use a mixture of equal parts of hydrogen peroxide and distilled water. Pour this mixture through the inner cannula. Do not soak. Rinse the inner cannula thoroughly with sterile normal saline or distilled water to remove all hydrogen peroxide.

Caution: Do not use cleaning agents such as alcohol, glutaraldehyde, or bleach. They will damage the inner cannula.

Reusable inner cannula care

1. Wash your hands.
2. Hold the neck flange steady with one hand.
3. With the other hand, grasp the twist-lock inner cannula connector and carefully unlock it using a counterclockwise motion.
4. Pull the inner cannula out of the tube, using a downward motion.
5. If you need to use a ventilator during this cleaning procedure, you may reconnect the ventilator to the tracheostomy tube without the inner cannula
6. Place the dirty inner cannula in a small wash basin containing sterile normal saline, distilled water, a solution of water, and a mild detergent or a solution of half hydrogen peroxide and half water. Use a small, nonabrasive brush or pipe cleaner to gently remove mucus.
7. After cleaning, rinse the inner cannula thoroughly with sterile normal saline or distilled water to remove all hydrogen peroxide.



8. Air-dry the inner cannula by gently shaking it.
9. Hold the neck flange steady with one hand.
10. Remove the spare inner cannula, if you used one.
11. Reinsert the clean inner cannula into the tube and secure it.
12. Clean the spare inner cannula if necessary, air-dry, and store in a safe place.

What you will need

- Disposable gloves
- Mild soap such as Ivory
- Hydrogen peroxide and sterile water (mixed in equal parts)
- Small nonabrasive brush or pipe cleaners
- Small wash basin
- Spare inner cannula if using reusable inner cannula tube
- Sterile 4 x 4 in. gauze

Read before starting inner cannula care



Caution: A Shiley™ disposable inner cannula should never be cleaned and reused. It is designed for one-time use only.

Note: The disposable inner cannula should be changed and discarded according to the schedule your doctor or home healthcare provider gives you.

Replacing a disposable inner cannula

The disposable inner cannula system eliminates the need to clean the inner cannula. The snap-lock feature provides a secure connection and makes it easy to insert and remove the disposable inner cannula with little or no discomfort.

1. Wash your hands.
2. Hold the neck flange steady with one hand.
3. With the other hand, gently squeeze the snap-lock or pinch tab and pull the inner cannula out of the tube, using a downward motion.
4. Throw away the used inner cannula.
5. Gently squeeze the snap-lock of the new inner cannula and insert it into the tube. Release the snap-lock connector when it securely locks onto both sides of the connector rim.



3

Read before cleaning your tube



Caution: Shiley™ trach tubes are designed for single-patient use only and cannot be resterilized by any method, including soaking and/or rinsing them in boiling water.

Note: Do not expose Shiley™ trach tubes to temperatures above 120 F.

Note: Do not expose Shiley™ trach tubes to any chemical agents, other than those listed above, because they may degrade the plastic (polyvinyl chloride). This will result in tube damage.

Note: Detergents with artificial colors, degreasers, or sterilizing/antibacterial ingredients may discolor the trach tube. They may also degrade the plastic (polyvinyl chloride) resulting in tube damage.

Caution: A Shiley™ disposable inner cannula should never be cleaned and reused. It is designed for one-time use only.

Name of Part	Hydrogen Peroxide and Water (1/2 & 1/2)	Normal Saline or Distilled Water	Water and Mild Detergent	Alcohol	Boiling in Water	Autoclave ETO/ Gamma	Betadine™ Solution
Reusable inner cannula	*Yes	Yes	*Yes	No	No	No	No
Disposable inner cannula	No	No	No	No	No	No	No
Outer cannula (cuffless)	No	No	No	No	No	No	No
Outer cannula (cuffed)	No	No	No	No	No	No	No
Decannulation plug (DCP)	*Yes	Yes	*Yes	No	No	No	No
Disposable decannulation plug (DDCP)	No	No	No	No	No	No	No
Obturator	*Yes	Yes	*Yes	No	No	No	No

*Do not use solutions other than those recommended. Hydrogen peroxide or other oxidizing agents may be harmful to the device.

Symptom	What May Have Happened	What To Do
Excessive air leak through nose and mouth.	Insufficient air in cuff (cuffed tubes only).	Deflate and reinflate the cuff with the proper amount of air.
	Leak in cuff, inflation line, pilot balloon, or luer valve (cuffed tubes only).	Replace the tube.
	Tube too small for trachea.	Call your doctor.
	You may have an uncuffed tube and need a cuffed tube.	Call your doctor.
	Fenestrated inner cannula is in the tube.	Remove it and replace it with a nonfenestrated inner cannula.
Tube comes out of the opening in the neck.	Excessive pulling or weight at the connector.	Hold the neck flange with one hand while disconnecting the ventilator tubing to reduce pulling. Move the ventilator if need be. Reattach the ventilator tube to the trach tube connector.
	Trach tube ties too loose or incorrectly tied.	Retie the trach ties (see page 9).
Difficult to remove or insert inner cannula for fenestrated tube.	Tracheal lining may be pushing through the fenestration.	Call your doctor.
	Trach tube alignment has changed.	Call your doctor.
Tube, or any part of the tube, breaks or doesn't work.	Excessive use or wear on the trach tube.	Replace the tube.
	Trach tube was cleaned using improper cleaning agents.	Replace the tube. Always use only those cleaning agents recommended by the tube manufacturer (see page 16).
	Excessive pulling or weight at the connector.	Hold the neck flange with one hand while readjusting ventilator tubing to reduce pulling. Move the ventilator if need be. Put the ventilator tube adapter back onto the trach tube connector.
	Trach tube ties are too loose or incorrectly tied.	Make sure tube is properly inserted in the trachea. Then retie trach ties (see page 9).

Symptom	What May Have Happened	What To Do
Unable or difficult to pass a suction catheter through trach tube.	Mucus is plugging the trach tube.	Remove inner cannula and clean it, if reusable. Replace it if disposable.
	Catheter is too large for the tube size.	Contact your doctor, nurse, or therapist for guidance in the size of catheter needed.
	Tube is not properly positioned in the trachea.	Reposition the tube.
	A fenestrated inner cannula is in the tube.	Replace it with a nonfenestrated inner cannula.
Ventilator's "High Pressure" alarm goes off.	Ventilator tubing is blocked or kinked.	Clear tubing of kink or block.
	Mucus is plugging the trach tube.	Suction to clear mucus.
	Excessive amounts of water have collected in the ventilator circuit, blocking airflow.	Drain the ventilator circuit of water or condensation.
	If the first three suggestions don't work, there may be a more serious problem.	Contact your doctor, nurse, or therapist immediately.
Ventilator's "Low Pressure" alarm goes off.	Ventilator tubing is not connected at machine.	Make sure all tubing to the machine and patient is connected.
	If you have a cuffed trach tube: There may be a leak in the cuff, inflation line, pilot balloon, or luer valve.	Remove the ventilator tubing from the trach tube. Deflate and reinflate the cuff with the proper volume. Replace the tube if it does not remain inflated. Attach ventilator tubing. Turn on the machine. If the problem continues, replace the tube.
	A fenestrated inner cannula is in the tube.	Replace it with a nonfenestrated inner cannula.
	If the first three suggestions don't work, there may be a ventilator problem.	Contact your doctor, nurse, or therapist. Deliver breaths with a manual resuscitation bag, if available.

Read before using Shiley™ trach tubes



Warning: The FEN and CFN are supplied with both a fenestrated and nonfenestrated inner cannula. Do not use the fenestrated inner cannula (green-colored connector) during mechanical ventilation.

Warning: Shiley™ decannulation plugs (DCP and DDCP) are designed for Shiley™ fenestrated tubes only. They are not interchangeable with other manufacturers' products.

Shiley™ Adult Tracheostomy Tubes

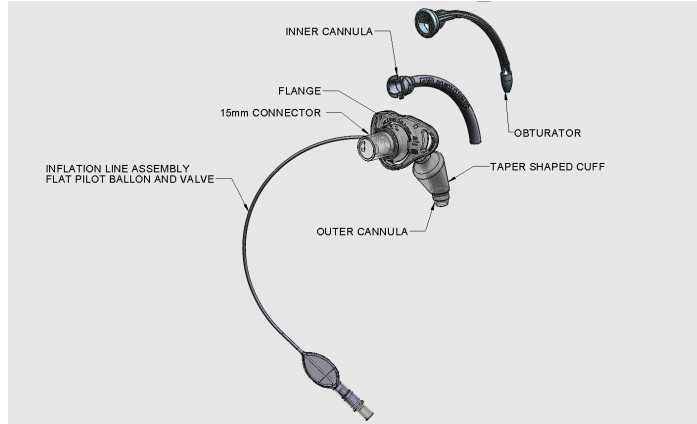

FEN, CFN, and LGT

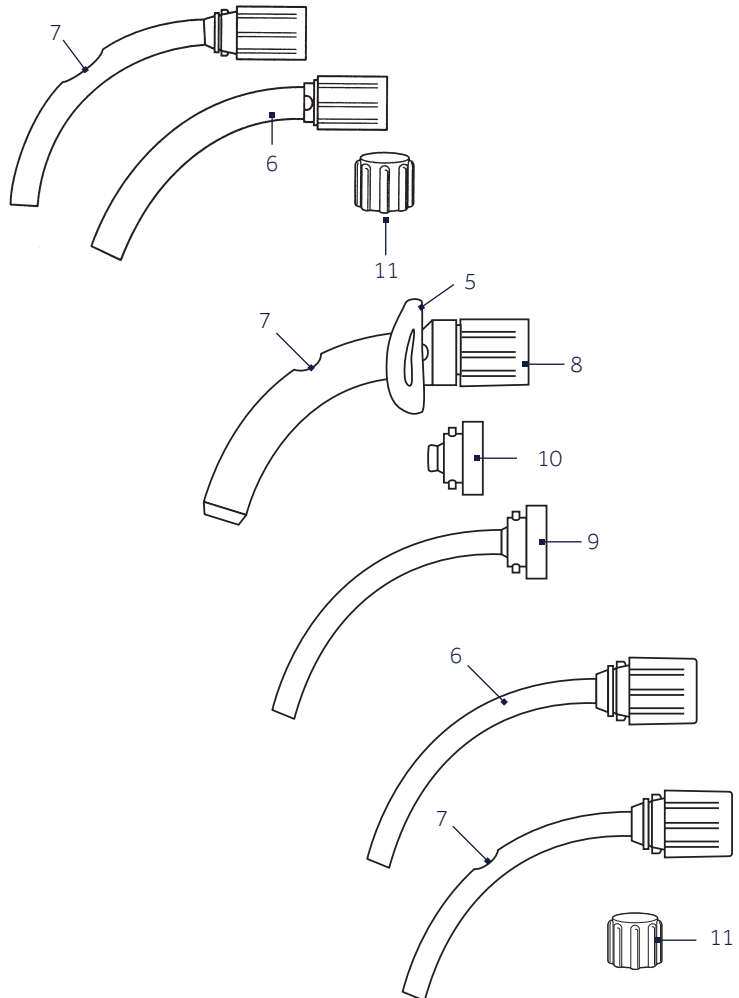

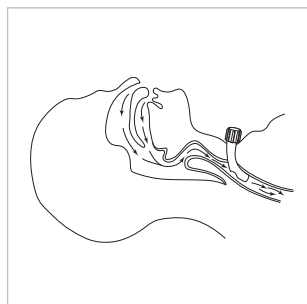

- 1. Cuff**

The “balloon” on the end of the trach tube. When inflated, it forms a seal against the wall of your windpipe. This stops the airflow through your mouth and nose so that you breathe through the trach tube. Some trach tubes do not have a cuff. Please consult your doctor if you have questions about the type of trach tube prescribed to you.
- 2. Inflation line**

Thin plastic tubing that carries air to and from the cuff.
- 3. Pilot balloon**

Small plastic balloon-like component on the end of the inflation line. Indicates if air is in the cuff.
- 4. Luer valve**

Where the syringe is connected to inflate or deflate the cuff.
- 5. Soft swivel neck flange**

Contains product designation and size information. Twill ties or Shiley™ trach tube holders attach through the holes on either side securing the tube to your neck. Soft swivel design helps to position the tube properly and comfortably.
- 6. Reusable inner cannula**

The tube that fits inside your trach tube. This can be easily detached and cleaned to remove mucus. FEN and CFN have a fenestrated inner cannula.
- 7. Fenestration**

A hole on the curved part of the trach tube or inner cannula. When a fenestrated inner cannula is used or the nonfenestrated inner cannula is removed, it allows air to flow through the vocal cords, mouth, and nose so you can speak.
- 8. 15-mm connector**

Part of the inner cannula that sticks out at the neck. An artificial nose, ventilator tubing, manual resuscitation bag, or Shiley™ phonate speaking valve may be connected to this.
- 9. Decannulation plug**

For use with FEN and CFN. Attaches to the trach tube opening when the inner cannula has been removed and the cuff has been deflated. Directs air through fenestration to your mouth and nose.
- 10. CAP**

Fits over the green 15-mm connector on the fenestrated inner cannula of an FEN or CFN when the cuff has been deflated. Directs air through fenestration to your mouth and nose so you can speak.

Read before using Shiley™ trach tubes



Warning: Shiley™ decannulation plugs (DCP and DDCP) are designed for Shiley™ fenestrated tubes only. They are not interchangeable with other manufacturers' products.

DFEN

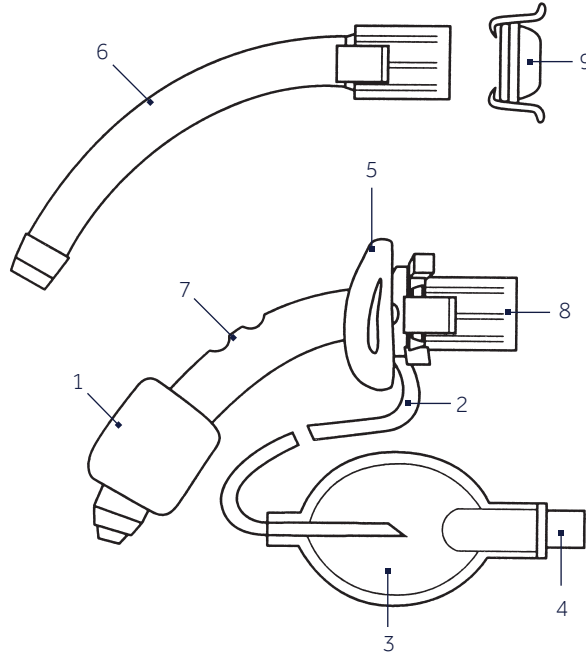

DCFN

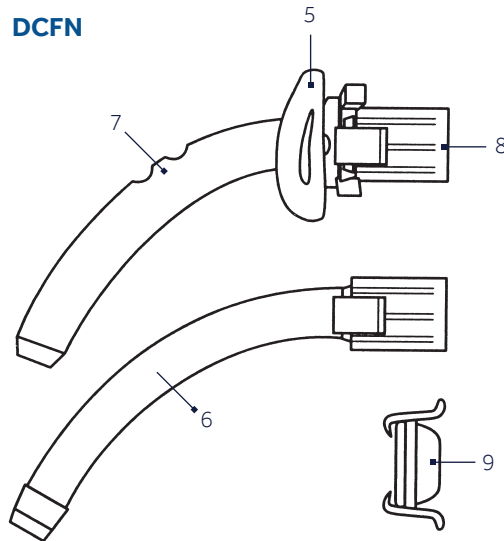

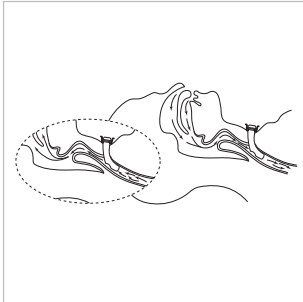

- 1. Cuff**

The "balloon" on the end of the trach tube. When inflated, it forms a seal against the wall of your windpipe. This stops the airflow through your mouth and nose so that you breathe through the trach tube. Some trach tubes do not have a cuff. Please consult your doctor if you have questions about the type of trach tube prescribed to you.
- 2. Inflation line**

Thin plastic tubing that carries air to and from the cuff.
- 3. Pilot balloon**

Small plastic balloon-like component on the end of the inflation line. It indicates if air is in the cuff.
- 4. Luer valve**

Where the syringe is connected to inflate or deflate the cuff.
- 5. Soft swivel neck flange**

Contains product designation and size information. Twill ties or Shiley™ trach tube holders attach through the holes on either side securing the tube to your neck. Soft swivel design helps to position the tube properly and comfortably.
- 6. Disposable inner cannula**

The tube that fits inside your trach tube. Designed for single use only. Do not reuse or clean. Replace with a new one as directed by your doctor or home healthcare provider.
- 7. Fenestration (DFEN and DCFN)**

A hole on the curved part of the trach tube. When the fenestrated outer cannula is used, the non-fenestrated inner cannula is removed, allowing air to flow through the vocal cords, mouth, and nose, so you can speak.
- 8. 15-mm connector**

Part of the inner cannula that sticks out at the neck. An artificial nose, ventilator tubing, manual resuscitation bag, or Shiley™ phonate speaking valve may be connected to this.
- 9. Disposable decannulation plug (DDCP)**

For use with DFEN and DCFN. Attaches to the trach tube opening when the inner cannula has been removed and cuff has been deflated. Directs air through fenestration to your mouth and nose.

SCT

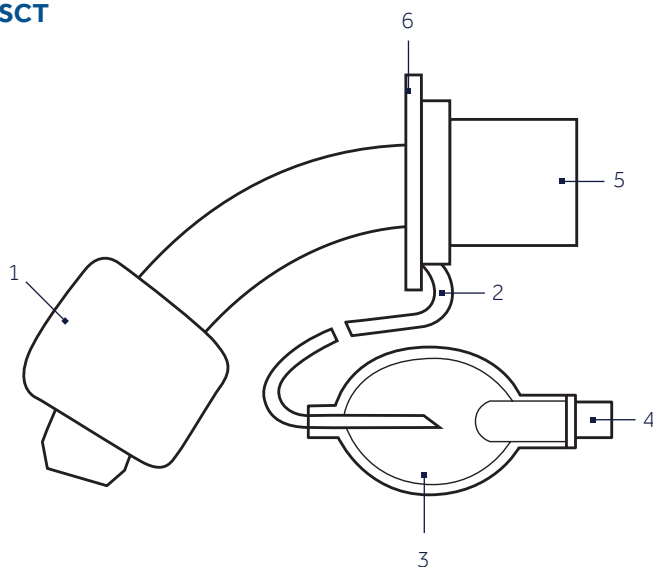

- 1. Cuff**
 The “balloon” on the end of the trach tube. When inflated, it forms a seal against the wall of your windpipe. This stops the airflow through your mouth and nose so that you breathe through the trach tube. Some trach tubes do not have a cuff. Please consult your doctor if you have questions about the type of trach tube prescribed to you.
- 2. Inflation line**
 Thin plastic tubing that carries air to and from the cuff.
- 3. Pilot balloon**
 Small plastic balloon-like component on the end of the inflation line. It indicates if air is in the cuff.
- 4. Luer valve**
 Where the syringe is connected to inflate or deflate the cuff.
- 5. 15-mm connector**
 Permanent part of the trach tube that sticks out at the neck. An artificial nose, ventilator tubing, manual resuscitation bag, or Shiley™ phonate speaking valve may be connected to this.
- 6. Neck flange**
 Contains product designation and size information. Twill ties or Shiley™ trach tube holders attach through the holes on either side securing the tube to your neck.



Warning: Ensure that oxygen tubing does not excessively tug or pull at speaking valve attachment.

The Shiley™ phonate speaking valve should only be used, on the order of a doctor, with patients who are alert and cooperative.

The Shiley™ phonate speaking valve should not be used during sleep.

The Shiley™ phonate speaking valve is not designed to be used by patients who are ventilator dependent.

Use the Shiley™ phonate speaking valve only with a cuffless tube or a fenestrated cuffed tube. If a cuffed tube is used, the cuff must be completely deflated. Do not use with foam cuff tubes.

Caution: Do not attempt to remove the flexible diaphragm from the valve cap.

Use the Shiley™ phonate speaking valve only after secretions have minimized following trach.

Pediatric patients should not use the Shiley™ phonate speaking valve with oxygen port (SSVO) unless the port cap is not accessible to the patient.

Note: The Shiley™ phonate speaking valve should only be used on the order of a physician. Your home healthcare provider will decide if the Shiley™ phonate speaking valve is right for you.

The Shiley™ phonate speaking valve should be replaced after 30 days of normal use.

Replace the Shiley™ phonate speaking valve should the flexible diaphragm become damaged, sticky, or malfunction in any way.

Shiley™ Speaking Valve (SSV/SSVO)

Description

The Shiley™ phonate speaking valve is designed to eliminate the need to use your finger to block the opening of your trach tube in order to talk. It is a one-way valve that attaches to the 15-mm connector of your trach tube, including pediatric sizes. It is available without an oxygen port (SSV) or with an oxygen port (SSVO).

Contraindications

The Shiley™ phonate speaking valve is not for use by patients who have laryngeal stenosis, vocal cord paralysis, severe tracheal stenosis, airway obstruction, respiratory infection, or heavy pulmonary mucus secretions.

How the Shiley™ phonate speaking valve works

When the phonate speaking valve is attached to the 15-mm connector or hub of a fenestrated or cuffless trach tube, the valve opens when you breathe in, allowing air to enter your lungs. When you breathe out, the valve closes and causes air to go up your windpipe and through your vocal cords, allowing speech.





Note: If oxygen port is blocked or obstructed, use a moistened cotton swab, with some of the cotton removed, or pipe cleaner, to gently remove any remaining debris or encrustation. Rinse again and reexamine. See complete cleaning instructions on the next page.

Note: The Shiley™ phonate speaking valve is designed for single-patient use only.

How to Use the Shiley™ phonate Speaking Valve

1. Wash hands thoroughly.
2. Carefully hold the trach tube with one hand while grasping the Shiley™ phonate speaking valve with the opposite hand.
3. Attach valve to the 15-mm connector using a gentle twisting motion. (Remove the Shiley™ phonate speaking valve if any respiratory distress or difficulty in breathing occurs.)
4. To remove the Shiley™ phonate speaking valve, carefully hold the trach tube with one hand, while pulling the device from the trach tube with a gentle twisting motion.
5. If using the phonate speaking valve for the first time, your home healthcare provider and/or speech pathologist will want to observe your breathing for a period of time to make sure you can breathe well around the trach tube and speak without difficulty.

Using the Shiley™ phonate Speaking Valve with Oxygen Port (SSVO)

To provide supplemental oxygen when the oxygen port is present, remove the oxygen port cap, connect the oxygen line tubing, and adjust the oxygen flow rate to prescribed setting.



Caution: Do not use a brush for cleaning as it will cause damage to the valve.

Do not use hot water as it will damage the valve.

Do not use bleach or alcohol to clean the valve.

Do not use ETO, autoclave, or radiation to sterilize the valve.

Cleaning

The Shiley™ phonate speaking valve should be cleaned daily while in use. If mucus or secretions become attached to the device, clean immediately.

1. Wash hands.
2. Remove the Shiley™ phonate speaking valve by carefully holding the trach tube with one hand, while pulling the device from the trach tube with a gentle twisting motion.
3. Open the valve cap by pressing the cap lid away from the body at a position opposite the hinge.
4. If an oxygen port is present, do not apply excess pressure to the side of the port when opening the cap lid.
5. Prepare one of the following cleaning solutions:
 - Cool or lukewarm saline
 - Soapy water (a pure soap such as Ivory™ brand is recommended)
 - Diluted household strength hydrogen peroxide (one part water and one part peroxide)
 - Diluted household strength vinegar (one part water and one part vinegar)
6. Soak the opened valve in the cleaning solution for up to 15 minutes.
7. After the soaking period, agitate the valve in the cleaning solution.
8. Thoroughly rinse the valve in cool or lukewarm tap water to remove all cleaning solution.
9. Examine the valve for remaining debris or encrustations. Ensure that the flexible diaphragm is clean, not torn or sticky, and that it lies flat in the valve cap.
10. Check inside the valve to make sure it is smooth and undamaged. If you have an oxygen port, use a pipe cleaner or cotton swab, with some of the cotton removed, to clean inside the port.
11. Close the valve by firmly pressing the valve cap onto the main body until it snaps in place.
12. When not in use, store the Shiley™ phonate speaking valve in a clean, dry place and protect from dust and moisture.
13. Always review use and cleaning instructions with your home healthcare provider or speech pathologist before using the Shiley™ phonate speaking valve.

Aerosol (air-o-sol)

A device that puts moisture into the lungs.

Artificial airway (ar-teh-fish-all airway)

Another word for trach tube

Artificial nose (ar-teh-fish-all noze)

Also called HME (heat and moisture exchanger). A device that fits on your tube to warm and moisten the air you breathe.

Bacteria (back-teh-ree-ah)

Germs.

CPR Cardiopulmonary resuscitation

A method for getting someone to breath again once they have stopped.

Cannula (can-you-la)

Inner cannula Removable inner tube.

Outer cannula

The outer part of the trach tube that is inserted into the trachea.

Cannulae (can-you-lie)

More than one cannula.

Cuff

The inflatable balloon on some trach tubes.

Sterile water

Water that is made by catching and cooling steam from boiling water. You can buy it at the grocery store.

Encrustation (in-cruss-ta-shun)

Hard, crusty, dried mucus.

Home healthcare provider

Nurses, nurse practitioners, doctors, respiratory therapists, speech pathologists, or others that visit your home.

Home healthcare supplier

The company where you get special medical equipment to use in your home.

Lumen (loo-men)

Inside part of the tube, where the air goes in and out.

Mucus (mu-kuss)

Slippery fluid that is produced in the lungs and windpipe. This sometimes dries and sticks to your tube.

Neck flange

The part of your trach tube where you attach twill ties or Shiley™ trach tube holders.

Obturator (ob-tur-a-tor)

The semirigid stick you put into the trach tube to help guide it into the opening in your neck.

Phonation (fo-nay-shun)

Talking or making sounds with your vocal cords.

Pliable (ply-ah-bull)

Soft, flexible.

Saline (say-leen)

Salt and water solution similar to water found in the body.

Secretions (see-kree-shuns)

Another word for mucus.

Speaking valve (spee-king valv)

A one-way valve that lets air come in through the trach tube, but then sends it out past the vocal cords and mouth to make talking possible.

Speech pathologist (speech pathol-o-gist)

A person trained to help people with speaking and swallowing problems.

Shiley™ phonate speaking valve

This compact valve fits on the end of your trach tube to help you speak more easily. Check with your doctor to see if you can use it. (For more information, see page 25.)



Shiley™ trach tube holder

This convenient alternative to twill tape comes in one size that fits pediatric to adult patients. Hook and loop fasteners easily attach to the trach tube neck flange. (Follow product instructions.) It is made of comfortable, latex-free foam-padded cotton.



Stoma (sto-ma)

The hole in your neck where you insert the trach tube.

Sterile (steer-ill)

Free from germs.

Suctioning (suck-shun-ing)

Removing mucus in the trach tube.

Syringe (seer-enj)

The plastic device the doctor uses to give shots, only there is no needle on it.

Trachea (tray-key-ah)

Your wind pipe.

Tracheostomy (tray-key-oss-tuhmee)

The opening in your neck where your trach tube goes, to make breathing easier.

Tracheotomy (tray-key-ot-o-mee)

An operation where the doctor makes an opening in your neck for a trach tube to make breathing easier.

Trach Tube (trake toob)

Short for trach tube. This is the tube the doctor puts in the opening in your neck to help you breathe.

Ventilator (vin-till-a-tor)

A machine that helps a person breathe.

Vocal cords (vo-cal cords)

Two strips of tissue in the voice box in the neck that vibrate to make sounds when you talk.